



31

ENERGY CONSERVATION

In the 1970s energy issues were dominated by the oil crisis and the threats to energy security. At that time environmental issues associated with the production and consumption of energy were yet to gain widespread attention. Nowadays, environmental issues are among top priority in private, public and government circle. Excessive energy use and growing exploitation of natural resources have adversely affected our environment. To reduce the adverse impacts of growing use of energy on the environment, it is important to improve energy use efficiency and switch to environment friendly energy sources. Improved energy efficiency and better energy management will help in preventing environmental damage and help in financial saving.



OBJECTIVES

After completing this lesson, you will be able to:

- *discuss the impact of energy use on environment;*
- *explain the importance of energy in daily life;*
- *explain the relation between energy and economic development;*
- *explain energy conservation with examples;*
- *explain how we can improve energy efficiency in industry;*
- *describe how we can conserve energy at various levels;*
- *describe the concept of energy efficient buildings and towns;*
- *describe the limitations of alternative sources of energy;*
- *define the concept of energy auditing.*

31.1 IMPACT OF ENERGY USE ON ENVIRONMENT

Energy use and supply is of fundamental importance to society which has made the greatest impact on the environment of any human activity Although energy and environment concerns

**Notes**

were originally local in character – for example, problems associated with extraction, transport or noxious emissions – they have now widened to cover regional and global issues such as acid rain and the “greenhouse effect”. Such problems have now become major political issues and the subject of international debate and regulation.

Apart from **depletion of energy resources**, use of energy especially burning of fossil fuels cause environmental pollution. Burning of fossil fuels emit green house gases that cause global warming. The changing weather patterns due to global warming are now a reality. The impact of global warming has already created an alarming situation and will soon become disastrous for the entire earth including the living creatures that have made this earth their home. We should better be cautious and aware to this to save our planet earth. To sum up, therefore, the impact of energy use on the environment has been two fold.

- Depletion of energy resources.
- Pollution of environment from emission of green house gases from burning of fossil fuels.

31.2 IMPORTANCE OF ENERGY IN DAILY LIFE

In an average home for almost all types of activities like lighting, cooling and heating the house, for cooking, for running televisions, computers and other electrical gadgets energy is used.

From the time you wake up to the time you go to sleep at night, energy has affected your life. Energy is important in everyone’s life, whether you notice it or not. Without it people would have a hard time waking up and an even harder time getting anywhere. Energy is important whether its solar energy, mechanical energy, nuclear power, or the energy your body makes that allows you to talk, move, and walk. These are the tasks that we normally do that involve energy, and that we couldn’t do without it.

You will probably pass a traffic light on your way to school or work place and that is powered by electricity. Without the traffic light, cars would be going all over the place and crashing all the time. Traffic lights help to manage the chaos. If you walked to school you used the energy your body made from converting calories from food to energy. You might turn on lights in your house, when it gets dark. Electricity allows you to light up the room and makes it bright.

In the transport sector, buses, trucks, trains, aeroplanes, ships, automobiles are powered by coal, gasoline, diesel and gas. These are fossil fuels and their over exploitation is causing scarcity.

In the agricultural sectors, pumps for irrigation run on diesel (a fossil fuel) or electricity. Tractors, threshers, combined harvesters are all fuel-intensive.

In the industrial sectors, energy is required in huge amount at various stages in the manufacturing of goods.

Energy has been universally recognized as one of the most important inputs for economic growth and human development. The energy sector in India has been receiving high priority in the planning process.



Notes

31.3 ENERGY AND ECONOMIC DEVELOPMENT

Energy development is an integral part of economic development. Economically developed countries use more energy per unit of economic output and have much more per capita energy consumption as compared to developing countries. Energy has been universally recognized as one of the most important inputs for economic growth and human development. Growth of economy will stand global competitiveness withstand only when it will depend on cost effective or cheaper and environment friendly energy sources.

Energy intensity is an indicator to show how efficiently energy is used in the economy. India's energy intensity is much higher than the emerging economies of other Asian countries.

Energy sector in India has been receiving high priority in the planning process. Government of India has recognized the fact that the energy sector can become a major constraint or hurdle in the achievement of a high growth rate or Gross Domestic Product (GDP). It has therefore called for an increase in the reform process and adoption of an integrated energy policy.



INTEXT QUESTIONS 31.1

1. Mention two most important impacts of energy use on environment.

2. Mention four important activities which you require energy in your daily life.

3. Which is the most important input or factor required for economic growth in today's world?

**Notes****31.4 ENERGY CONSERVATION**

As you have already learnt, that industrial development and modern means of transport and various types of gadgets require increasing amounts of energy. Fossil fuels are universally the main source of energy which are finite and non renewable. It is therefore necessary to prevent wastage of energy and make all our efforts for energy conservation. The use of fluorescent light bulbs, energy efficient appliances and low emissive glass could reduce energy consumption significantly. We shall fail in our duty, if energy sources are exhausted. We owe our responsibility towards the next generation.. Energy conservation must become an everyday duty of every human being. Sincere efforts are needed at individual, community and at government level for energy conservation.

31.4.1 Conservation of energy at various levels**(A) Energy conservation at household level**

In every country residential demands constitute major part of total energy used. When comparing an average house to our energy efficient house, it is possible to reduce annual energy bills up to 40%. We should develop an energy conservation plan for our house. This is both an environment friendly and economically sound action.

The steps in developing an energy conservation plan for our home are (1) identify the problem areas where energy is being lost or inefficiently used. (2) to prioritize the problem areas according to how much energy is being lost or inefficiently used and (3) systematically correct the prioritized problems according to the limits of our household energy improvement budget.

Apart from lights and fans, several other household appliances have flooded the market. A cautious operation and use of good quality electrical appliances (with five star rating) not only enhance their life but also save energy. Some energy conservation activities are mentioned below:

(i) Major appliances for domestic use

Large appliances are the major consumers of energy and improving the operating efficiency of such household appliances will significantly reduce the overall consumption of electricity.

(a) Refrigerator

Do you know that refrigerators account for the consumption of a huge amount of energy? Condenser is found either behind the fridge or underneath the fridge and helps in maintaining its lower temperature. We can conserve energy while using refrigerator in the following ways:

- It should be maintained at 37°F- 400^o F and freezer section at 50°F and should have automatic moisture control.

- We should keep the fridge as full as possible and it should be kept in that position that its outside surface is not exposed to direct sunlight.
- If the door of the fridge is not closed properly it will consume much more energy. Uncovered liquids should not be put in the refrigerators as it will give extra workload to the compressor.
- Before putting food in the refrigerator it should be cooled up to room temperature.
- Door of the fridge should not be opened several times.

(b) Ovens/Microwave oven

To conserve energy while using ovens we should keep in mind the following:

- We should use microwaves as they consume 50% less energy than conventional ovens.
- The oven door should not have any cracks or tears in it.
- We should use “lids-on” cooking to permit temperature over heating.
- Keep reflector pans beneath stove top heating elements bright and clear.
- Carefully measure water used for cooking to avoid having to heat needed.
- Begin cooking on highest heat until liquid begins to boil. Then lower the settings and allow food to simmer until fully cooked.
- One should cook as much of the meal in the oven at one time as possible.
- Rearrange oven shelves before turning your oven on and do not peep in oven. Every time the oven is opened temperature is lowered by 4° - 5°C.
- When preheating an oven for baking, time the preheat period carefully, minutes should be sufficient.
- For large items, stove-top cooking is most efficient, especially with gas.

(c) Ironing

Everyday we iron our clothes. It consumes approximately 1000-watt energy, which is a huge amount. But we can save energy by ironing clothing in bulk and not just one or two at a time. Ensure that the thermostat on the iron is working and set the right temperature for the clothing being ironed.

(d) Cooking

Major part of energy is consumed during cooking. It can be saved during cooking by using all these measures. Use a cooking pan that is slightly bigger than your cooker plate, coil or burner. Keep saucepan lids on. Turn down the heat once food starts boiling.



Notes

**Notes****(e) Washing machines**

Washing machines consume 20% of the electricity. Energy can be conserved during the use of working machine in the following ways:

- We should try to use cold water while working and rinsing as almost 90% of the energy consumed by washing machine is used to heat the water.
- Follow detergent instructions carefully. Adding too much detergent for effective working action may require more energy.
- Wash only full loads of clothing but do not overload machine.
- Soak or prewash the clothes for effective cleaning as well as to reduce energy consumption.

(ii) Lighting

Increasing energy demand the world over and the ever-increasing prices of energy have provided a justifiable reason for improving energy efficiencies of all energy intensive technologies. Some methods of saving energy during lighting are as follows:

- Light should be turned off when not in use.
- Maximum sunlight should be used during the day. Bulbs and tubelights should not be used during day.
- Use task lighting whenever possible instead of brightly lighting an entire area or room.
- Use compact fluorescent lamps (CFL) in place of incandescent bulbs. A 23-watt compact fluorescent bulb can replace a 90 or 100 watt.
- Use dim light in galleries, lobbies; balconies etc.
- Do not keep computer, TV, tape recorder, music system in stand by mode. Do you know how much electricity you can conserve by turning off the TV instead of keeping it on stand-by? You can save 70-kilowatt hour per year.
- Geysers consume the maximum amount of electricity. Thermostat can be set to a lower temperature 45°C to 50°C.
- Lamps should be put in those corners of the rooms where they can reflect many light surfaces instead of one.
- Use dimmable bulbs wherever possible.

(iii) Electricity conservation

With the growing awareness about the depletion of global energy reserves and adverse environmental impacts of energy use, now efforts are underway to develop energy efficient

machines and technologies to reduce energy expenditure and to minimize environmental hazards. Some such steps are as follows:

- Use ISI marked appliances and equipments.
- Substitute bulbs with tungsten filaments lamps (TLP) tubes.
- CFL (compact fluorescent lamps) should be used as they use comparatively less electricity and last longer.
- Electric geyser can be replaced by gas geyser to save electricity.

(iv) Others

Some other methods by which energy can be saved are as follows:

- Adjust the flame of gas cooking appliances, so that the flame remains blue not red or yellow.
- Shut down computers when not in use.
- Select appliances (i.e. curling irons, coffee pots, irons) with time limited shut off switches.
- Replace aging old appliances, TVs and VCRs when needed, with energy efficient models.

(v) Cooling

A huge amount of energy is wasted in cooling. Following cooling measures can be taken to conserve energy:

- We should open windows at night, to bring cool air inside.
- Windows should be closed during daytime.
- West facing windows should be shaded. A whole house fan can be used to draw cool night air into the house.
- An evaporative cooler should be installed.
- Use room air conditioning only where needed and install energy efficient models.
- Cooling in air conditioned houses should be maintained at 25°F.
- Regular cleaning of filter in air conditioning systems and cleaning of condenser conserve energy.

(B) Energy conservation at community level

Energy conservation is a very sensitive issue throughout the world. In a society where money and especially saving of financially advantageous options are available to us, we should follow the following measures to reduce energy consumption-



Notes

**Notes**

- All unnecessary lights should be turned off especially when conference rooms etc. are not in use.
- Energy uses should be minimized during peak demand hours.
- Set computers, monitors, photocopiers and other business equipments to their energy saving mode. Turn them off during long idle hours such as lunch breaks.
- Skylights should be used for warehouses.
- Ensure that offices having air conditions have proper windows and all doors are closed when the air conditioner is in use.

(i) Use of renewable energy resources

Alternative resources i.e. renewable energy sources should be used in place of non-renewable energy sources e.g. solar energy, biogas, wind energy etc. Energy audits of homes, buildings, hotels and factories should be done at regular interval.

Demonstration of projects involving the introduction of appropriate, renewable solar technologies at the community level like solar pumps for water purification and irrigation of lawns, play grounds, gardens, community centres, as well as solar energy for cooking and heating should be promoted. Projects involving wind-generated energy for community and municipal needs should be demonstrated to the whole community. Demonstration of biogas programmes (see lesson 30) is also required to tell people for the efficient use of it. Collaborative community/ academic research and development in order to produce low-cost, sustainable energy options should be given priority.

Environment friendly public transport system should be promoted to reduce the use of individual motorized transport. For a single purpose minimum number of vehicles should be used. It will be also helpful in reducing CO₂ emission.

(ii) Energy conservation at community level for housing complexes

We require energy for all kinds of work. Cooking, lighting, cooling, transportation etc. But often the amount of energy which we use is comparatively much less than the amount of energy which is wasted. As the energy sources are fast depleting, it is necessary for us to save energy. At the community level following measures can be used:

- Installation of photoelectric controls or timers should be used to make sure that outdoor lighting is sufficient during the day. Open area or yard area lightings should be switched off after sunrise and again switched on only after sun sets. Tube lights in common area and staircase landings should be reduced and twin tubelight should be replaced by one tube light. Number of electrical lighting points could be reduced to one point per room. All additional fittings may be removed permanently or switched off.
- Water pumps should be switched off during non-peak utility hours.

- Elevators/lifts should be used for going up beyond three floors and for coming down the usage of lifts may be reduced. Whenever two elevators/lifts are provided in a building only single should be operated during “non-peak” hours. Do not allow children to play with elevators.
- Environmentally sustainable transport will promote more mileage less pollution by GHG gases.
- Conservation and sustainable use of water bodies, including watersheds, rivers barriers and coastal zones will be helpful in the energy conservation at community level.
- Training programme about energy efficient repairs should be organized to conserve energy at community level. Advocacy to remove subsidies to inefficient and polluting sources of energy should become essential. Locally manufactured, improved cook stoves should be introduced to reduce charcoal/fuel consumption.



Notes**(C) Energy conservation in industry and other places**

Energy conservation is the practice of decreasing the quantity of energy used. It may be achieved through efficient energy use, in which case energy use is decreased while achieving a similar outcome, or by reduced consumption of energy services. At different places such as factories, business centres, transportation sector and construction activities, it can be saved in the following ways:

(i) At factories and business centres including shops**(a) Auditing**

Regular monitoring and audit of energy consumption results in energy conservation.

(b) Process modification

Process modification means replacement of old and more energy consuming processes by the new energy efficient processes. Old factories should now employ process modification.

(c) Improved measuring instruments

We can use new technologies and energy efficient instruments and processes to conserve energy.

(d) Energy loss reduction

A lot of energy is wasted everyday. We can reduce energy loss by using following measures, for example: thermal insulation of fuel tanks can be done, Ceramic fiber sealing of furnaces, electrical tracing of liquid fuel lines instead of conventional steam heating.

(e) Light load reduction

A significant amount of energy can be saved by reducing light load. Bulbs have been replaced by tube lights. Nowadays CFLs have proved very helpful in reducing energy needs for lighting purposes.

**Notes****(D) Energy conservation in transportation sector**

Transportation includes all vehicles used for personal or freight transportation. Do you know of the energy used in this sector, approximately 65% is consumed by gasoline powered vehicles, primarily personally owned. Diesel powered transport (trains, merchant ship, heavy trucks etc.) consume about 20% and air traffic consumes most of the remaining 15%. Energy can be conserved in transportation by the following ways:

(i) Reduction of fuel consumption

Fuel consumption can be reduced in the following ways:

- Use public transportation as much as possible instead of using own vehicles.
- Car speed should be maintained as far as possible 50 to 60 km/hr.
- Do not use choke unless necessary, when choke is used, put it off as soon as engine is warmed up, if there is a starting trouble, press clutch to start the engine.)
- Avoid free frequent starts and stops to reduce fuel consumption. Release clutch pedal gradually and simultaneously press accelerator to racing and or jerking.
- Never race engine when declutched. Declutch fully when changing gears on clutch pedal because this increases clutch wear and fuel consumption.
- Do not run on hand brake and preferably install a warning light device. Apply brakes gradually as far as possible. Anticipate need for braking. Switch to lower gears on gradients (up/down) at the right time. All these will be helpful in reducing fuel consumption
- If possible it is always better to live near workplace.

(ii) Fuel economy- maximizing behaviour

Fuel economy maximizing behaviour describes techniques that drivers can use to optimize their automobile fuel economy. The energy in fuel consumed in driving is lost in many ways including engine inefficiency, aerodynamic drag, rolling friction and kinetic energy lost due to braking. They include following measures-

- moderate driving
- driving at lower speeds
- using cruise control (speed control or auto cruise controls speed and maintains steady speed by the driver).
- turning off a vehicles engine at stops rather than idling;
- a vehicles gas mileage decreases rapidly at highway speeds, normally above 55 miles per hour (though the exact number varies by vehicle).



INTEXT QUESTIONS 31.2

1. Name any one purpose for which the community may install a solar pump.

2. Why should we replace the ordinary bulbs in our house by CFL bulbs?

3. Why should there be regular monitoring and energy audit at work place?

4. What is car pool and how can car pool help in conserving petrol?



Notes

31.5 CONCEPT OF ENERGY EFFICIENT BUILDINGS

31.5.1 Energy efficient devices

Day by day we see that the demand of energy is increasing all over the world and as the demand is increasing energy prices are also increasing. Therefore, it is very necessary to develop energy efficient devices to save energy.

Compact Fluorescent Lamps (CFL) replaced incandescent bulbs. Open utensils cooking have been replaced with pressurized steam cooking and of course solar cooking. Many energy efficient devices can be manufactured and many technologies can be used for energy conservation. In many industries older and inefficient equipment has been replaced by new and efficient ones.

Other energy efficient devices which can be used for energy conservation are diamond hot plate, PRP bullock cart, tubelight with electronic ballast device which helps in reducing energy consumption by limiting amount of electric current in an electric circuit. Diamond mono-block lathe, natural water cooler, improved crematoria etc. (Fig. 31.1 a, b, c)

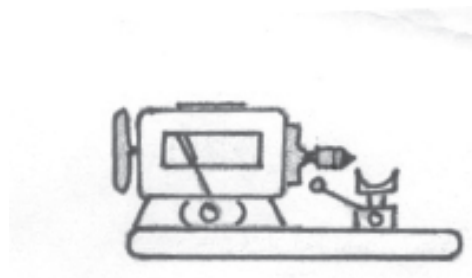
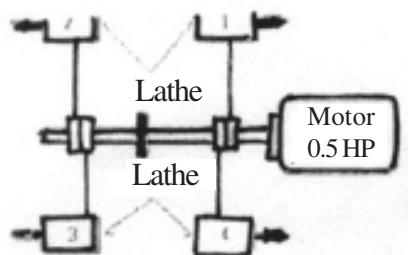

Fig 31.1 (a): Monoblock lathe (Q) consumes 80% less energy than conventional lathe (P)



Notes

Natural water cooler is a safe drinking water device which works on the principle of “cooling by evaporation”. No external source of energy such as electricity or ice is required.

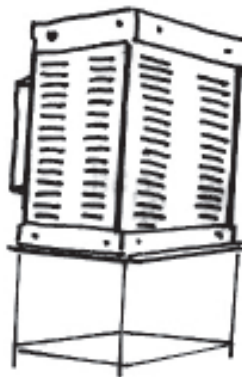

Fig. 31.1 (b): Natural water cooler

Promoted by government of Gujarat, India, improved crematoria are prefabricated cradle like iron structures designed for proper aeration for proper combustion. Consumption of wood for cremation is much reduced and consequently trees prevented from being axed.

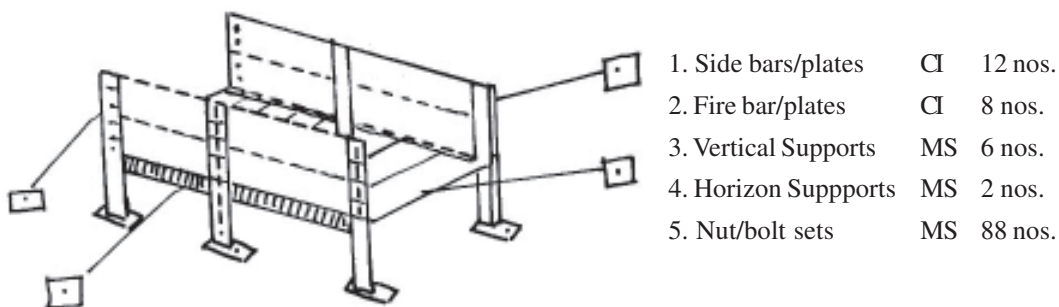

Fig. 31.1(c) Improved crematoria

31.5.2 Energy efficient buildings

Many energy efficient houses were made to save energy. Different types of new technologies were used to make them energy efficient. Some examples of such energy efficient buildings are as follows-

(i) Eco house

It is a residential building and was constructed in mid seventies. It was equipped with solar cooker and a multifeed biogas plant. Rain water harvesting is also used in this house. A roof mounted wind generator was also contemplated but not installed. Following technologies were used in this house-

- Rainwater harvesting with underground cistern.
- Roof integrated solar water heater.

- Window mounted retractable solar cooker.
- Multifed biogas plant, usable as septic tank, if required.
- Three different types of experimental roofs (hollow concrete tiles, Prefab brick jack arches, Madras terrace roof).
- Design for ventura (ventilation via inner courtyard). (Fig. 31.2)



Notes

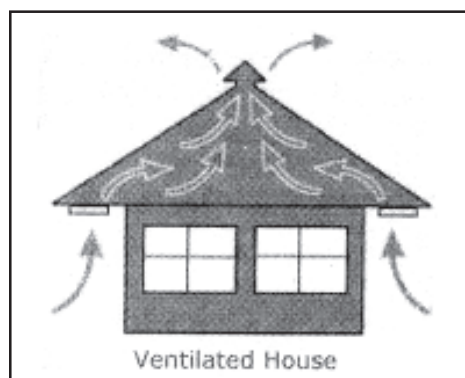

Fig. 31.2: Ventura system of using high and low pressure for sucking in cool air and pushing out hot air through roof ventilator

(ii) The Auroville visitors centre

It is a public building constructed in Pondicherry 1989. Several cost effective and alternative technologies had matured by mid eighties. Attempts to integrate everything in a functional and pleasing environment was quite successful and won the Hassan Fathy International award in 1992. The following technologies and equipment were used during its construction.

- Compressed earth blocks
- Ferro-cement roof channels and building elements
- Solar chimneys
- Wind pump
- Water solar PV pump
- Wind generators
- Decentralized waste water system.

(iii) Solar kitchen

It is a community kitchen and constructed for preparing 2000 meals a day. This concept began to be implemented in 1994. Since solar energy is abundant in southern India, using steam as the heat transfer medium for preparing the meals was the obvious choice. Solar kitchen possesses the following features (Fig. 31.3)

- Compressed earth blocks



Notes

- 10m long ferro-cement roof channels
- Decentralized waste water system consisting of Imhoff tank (Fig. 31.4), baffled reactor and polishing pond (Fig. 31.5).
- Solar bowl concentrator of 15m diameter.
- Scheffler community cooker concentrator (Fig. 31.6).

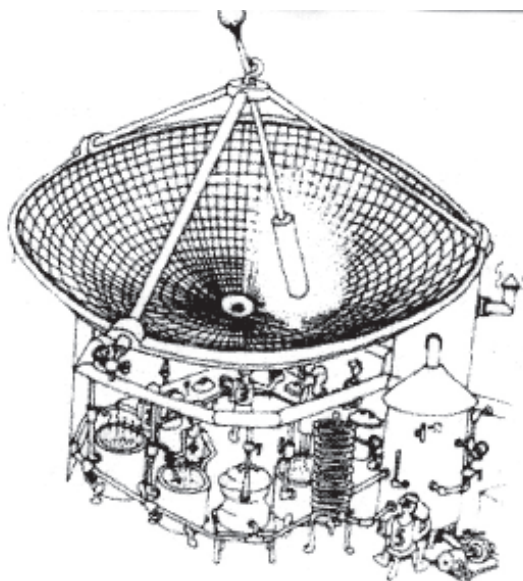

Fig. 31.3: Solar kitchen

A collective kitchen for Auroville community, the solar kitchen has a big “solar-bowl” on its roof.

Imhoff Tank is a septic tank with improved technology for waste water treatment.

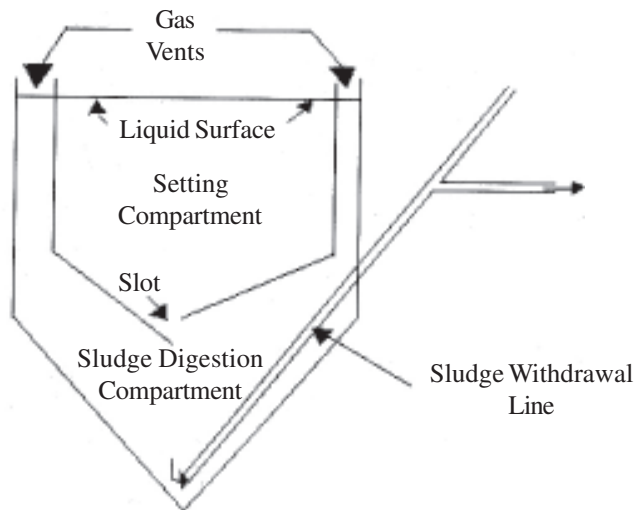

Fig. 31.4: Components of Imhoff tank

Oscillatory baffled reactors are in demand in chemical and pharmaceutical industries for efficient use of reagents, solvents and energy. The waste produced is minimized.

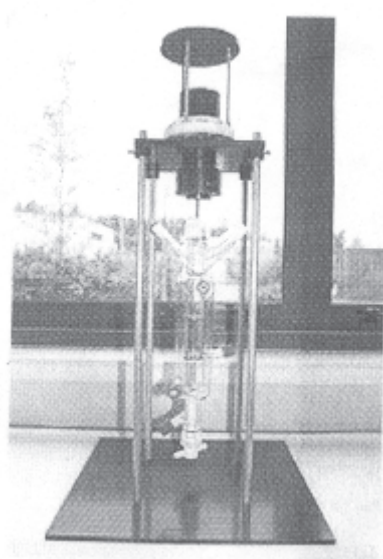

Fig. 31.5: Lab-scale batch OBR



Notes



Fig. 31.6: Scheffler community cooker concentrator



INTEXT QUESTIONS 31.3

1. Expand CFL.

2. Name the equipment which uses wind as a source of energy at Auroville in Pondicherry.

3. What is the concept of an energy-efficient town?

**Notes****31.6 CONCEPT OF ENERGY EFFICIENT NEW TOWNS**

Energy conservation should be considered in any comprehensive land use planning process. A variety of heating sources like fuel oil, gas, wood, electricity, the sun and coal etc. are used in homes and business houses. This energy consumption and conservation of energy resources is the hot topic these days. Substantial economic savings can be realized through energy conservation.

Effective use of land could prove to be a good way of energy conservation. The design of the town should be such that developmental densities should be highest towards the centre of the town, which is served by municipal water and sewer. Outlying areas should have much less constructions.

A township can be oriented towards becoming eco-friendly only with the cooperation of the inhabitants. A township may have structures of eco-friendly architecture but unless the inhabitants resolve and practice energy conservation and eco-friendly way of life, the purpose of energy efficient town would be defeated. Education, eco-friendly behaviour and ecologically sound infrastructure can truly create energy efficient green towns.

(i) Education

Education is the best way of creating awareness for energy conservation. A branded programme can be created with a title and logo to imprint the conservation message on all township communities and documents. Energy conservation information should be present on the websites, local cable access station.

(ii) Changing behaviour

For right attitude towards energy conservation residents should be encouraged to drive less, walk and bike more by installing bike racks at public buildings.

A best way to conserve energy is to switch off the lights while leaving the room, shut down the computers when not in use. When appliances are not in use they should be unplugged. Lower the thermostats in the winter and raise them in the summer.

Household and business wastes should be recycled. It will positively result in energy conservation.

(iii) Greening our infrastructures

Light bulb should be replaced with the energy efficient compact fluorescent bulbs as they use 75% less energy and last up to ten times longer than standard incandescent bulbs.

Appliances and office equipments should be replaced with energy star rated units. It will lower energy usage and costs.

Green buildings

Currently this method is expensive. But energy conservation elements that are not higher in cost than that of traditional products can be used.

Besides, the setting, design and construction of buildings strongly influence the amount of energy needed for heating, cooling as well as for lighting. Proper design, building orientation, construction, and landscaping provide opportunities for energy conservation measures such as passive solar space, domestic hot water heating mechanism, natural lighting and photovoltaic electricity production. Besides, renewable energy sources should be used more instead of non-renewable energy sources. Other measures which will be helpful in energy conservation are as follows-

- (i) Building designs and construction practices should promote energy conservation.
- (ii) Use of renewable energy sources should be encouraged.
- (iii) Facilitate energy conservation as related to local transportation needs.
- (iv) Awareness should be raised among people for conservation of energy sources.
- (v) Promote community self-sufficiency and independence with respect to energy levels and encourage the use of the least environmentally damaging sources of energy.
- (vi) Town should minimize its energy consumption.

31.7 LIMITATIONS OF ALTERNATE SOURCE OF ENERGY

Once humans became aware about the limited stocks of fossil fuels, use of renewable sources of energy began. Currently the sources of energy in global use are:

- (1) fossil fuels (coal, oil and natural gas) – 88%
- (2) nuclear energy (Fission and fusion of atoms) – 05%
- (3) other sources (hydel, tidal, wind, geothermal, solar, fuel wood, solid waste and biomass conversion energy) – 07%

You are well aware now about the limitations and impacts of use of fossil fuels. You have already learnt that the other sources mentioned above are renewable but they have their limitations as tabulated below:



Notes



Notes

Table 31.1: Limitations of alternate sources of energy

Source of energy/Fuel	Production	Advantages	Limitations
Nuclear energy	Nuclear fission (splitting of atom) and Nuclear fusion	No air pollution Fuel efficient	<ul style="list-style-type: none"> High cost of construction of nuclear plant. Fear of security and nuclear accidents. Problem of safe disposal of nuclear waste.
Hydel power or Hydropower	Dams built on river for electricity generation	World's hydro electricity capacity high	<ul style="list-style-type: none"> Ecosystems behind dams disturbed. Human settlements up rooted for building dam. Habitat loss and consequent biodiversity loss. Developmental cost high. Fertile farmland lost and amount of nutrient rich silt on down river agricultural fields reduced.
Solar energy	From natural sunlight	Environment friendly Ample or unlimited availability.	<ul style="list-style-type: none"> Limited capacity for storage of sunlight. Cloud cover may man usefulness. Collecting equipment expensive.
Wind energy	Fans for directing winds in use from long for irrigation crops	<ul style="list-style-type: none"> No pollution Available for free 	<ul style="list-style-type: none"> Not available everywhere or intermittently available. Fans of wind mills visual hazards for flying birds and aeroplanes (visual pollution).
Tidal energy	Harnessing tidal power by suitable structures	Free and clean	<ul style="list-style-type: none"> Structures (plant) used for harnessing energy expensive. Plant disrupts natural flow of estuary and concentrate pollutants in the area.
Geothermal energy	Wells drilled to trap steam which powers electrical generators. Steam naturally produced from underground water which gets heated due to very high temperature that region.	Environment friendly	<ul style="list-style-type: none"> Steam contains Hydrogen Sulphide (H₂S) having odour of rotten eggs. Minerals in the steam corrosive to pipe lines and equipment causing maintenance problems. Minerals in the water toxic to fish.
Biomass (1) Fuel wood	Cutting trees for fuel wood and burning them straight away	Cheap so popular in under developed and developing countries	<ul style="list-style-type: none"> Comparatively low level of energy. Bulky so difficult to transport. Burning wood causes air pollution. Destruction of forests to obtain fuel wood and so desertification. Release lot of fly ash.
(2) Biomass conversion	Obtaining energy from chemical energy. Stored in biomass (or live material). Burned directly for cooking or to produce electricity converted to ethanol or methane (biogas)	Renew able energy	<ul style="list-style-type: none"> May lead to food shortage because nutrients not returned to soil from biomass. Growing maize for ethanol requires more energy expenditure than the amount of energy in the form of alcohol retrieved. Land for growing food used for growing biomass for conversion into fuel.
Solid waste	Waste sorted and burnable material separated	<ul style="list-style-type: none"> Decreases cost of fresh disposal Reduces need for land fill sites 	<ul style="list-style-type: none"> Causes air pollution for burning releases CO₂ and other gases. Waste such as bleached paper and plastics have chlorine containing compounds which form dioxins which are highly toxic and suspected to be carcinogenic.

31.8 CONCEPT OF ENERGY AUDITING

Energy auditing is a systematic approach to monitor industrial energy consumption and to find out the sources of energy wastage. It consists of activities that seek to identify conservation opportunities before conducting or developing any energy saving program.

These audit programs are helpful in understanding and analyzing the energy utilization of any organization. The audit programmes help to identify and reduce energy wastage.

The role of an energy audit

The first and most important role of energy auditing is to identify the areas of energy consumption and to find the overuse for accessing the opportunity of saving energy. In this way, money can be saved for example during the audit of a factory; the employees of the factory can be trained for the use of energy saving equipment. Also they would be made aware of the need for energy conservation. So there is an attitudinal change for reducing energy use and energy wastage.

It is amply clear that energy auditing plays an important role in energy conservation.

Analysis of energy use

Analysis of energy use is done for identifying the areas of energy consumption. This analysis can be used in the review of management structures and procedures for controlling energy use. Sub meters can be installed in different plant locations to pinpoint the actual energy consumption per area. This data could be helpful in allocating energy use. With the help of this plant manager can list all the equipment used and the corresponding operating hours. This information can play an important part in creating spreadsheet information and the charts resulted by can prove useful for analysis.



Notes



INTEXT QUESTIONS 31.4

1. What is the role of energy auditing?

2. Give one limitation for each of following renewable source of energy (i) hydel power (ii) geothermal energy (iii) nuclear energy

3. Give one advantage for each of the following renewable source of energy (i) solar (ii) biomass (iii) wind.



WHAT YOU HAVE LEARNT

- Impact of energy use on environment. Impact of energy use in daily life.
- The relationship between energy and economic development.

**Notes**

- The concept of energy conservation and how it could be saved at various levels.
- Different new energy efficient devices and technologies should be used to conserve energy.
- Methods of conservation of energy at individual and community levels and at industries.
- Awareness among people about the concept of energy conservation could prove very helpful.
- Some new technologies can be used while building construction to save the energy limitations of alternate sources of energy.
- By the help of auditing, we can come to know the areas where energy consumption is higher and accordingly we can plan to reduce the usage of energy to save it.

**TERMINAL EXERCISE**

1. What is energy conservation and how can it be conserved at household level?
2. How is energy conservation possible while constructing buildings? Explain with the example of some energy efficient buildings.
3. What are energy efficient devices? Give some examples of such devices.
4. How can energy efficient towns be designed?
5. Define the concept of energy auditing. How can it be helpful in energy conservation?
6. Mention the advantages and limitations of using solar energy.
7. Write short note on importance of energy in your daily life.
8. Justify the statement that ‘the energy is most important input for economic growth and human development.
9. How can we conserved energy at community level for housing complexes

**ANSWER TO INTEXT QUESTIONS****31.1**

1. Depletion of energy; emission of green house gases due to burning of fossil fuel.
2. Cooking, heating and cooling of houses, TVs and computers and electrical gadgets.
(Any other)
3. Population

31.2

1. Water purification/irrigation
2. They use much less electricity and last longer.
3. To reduce energy consumption/ to conserve energy.
4. Car pool is sharing of cars for going to work place. Much petrol is wasted when each person takes his own car to travel to same place.

31.3

1. Compact Fluorescent Lamp
2. Wind pump
3. A township whose constructions are eco-friendly and inhabitants are eager to conserve energy resources.

31.4

1. Systematic approach for monitoring industrial energy consumption and identifying sources of wastage.
2. (i) Ecosystems/human settlements disturbed/ habitat loss/ biodiversity loss/ high developmental cost (any one)
(ii) Smelly H_2S released/ pipelines corroded/ toxic minerals released. (any one)
(iii) High cost of construction of nuclear plant/ fear of security and nuclear accidents/ problem of safe disposal of nuclear waste. (any one)
3. (i) Environment friendly, cheap so popular in underdeveloped and developing countries
(iii) No pollution, available for free.



Notes